



# Solar Solutions

Reliable and Process Optimised  
Solar Adhesive Systems



Innovation & since  
Consistency | 1910

# Adding Value with Adhesives and Sealants for Assembly and Installation

Sika takes pride in delivering products and solutions that will last decades under harsh environmental conditions and in its 30 years successful experience in the facade and 15 years in the renewable energy industries. The range of solar applications may be extremely varied, but systems share the same need for outstanding performance. Solar systems have to consistently deliver the required output to give returns on long-term investments, even though facing tough conditions over long periods. The solar industry is pressed by the demand to provide product durability and at the same time keep costs competitive.

To help you meet these challenges, Sika can offer state-of-the-art solutions developed over its long term experience in automating adhesive application for the automotive and allied industries. Our adhesive systems for the solar industry have been optimized to provide improved performance, curing speeds and increased process capabilities.

These factors, together with a comprehensive and worldwide project support, make Sika an ideal partner to manufacturers of Photovoltaic, Solar Thermal and Concentrating Solar Power systems.

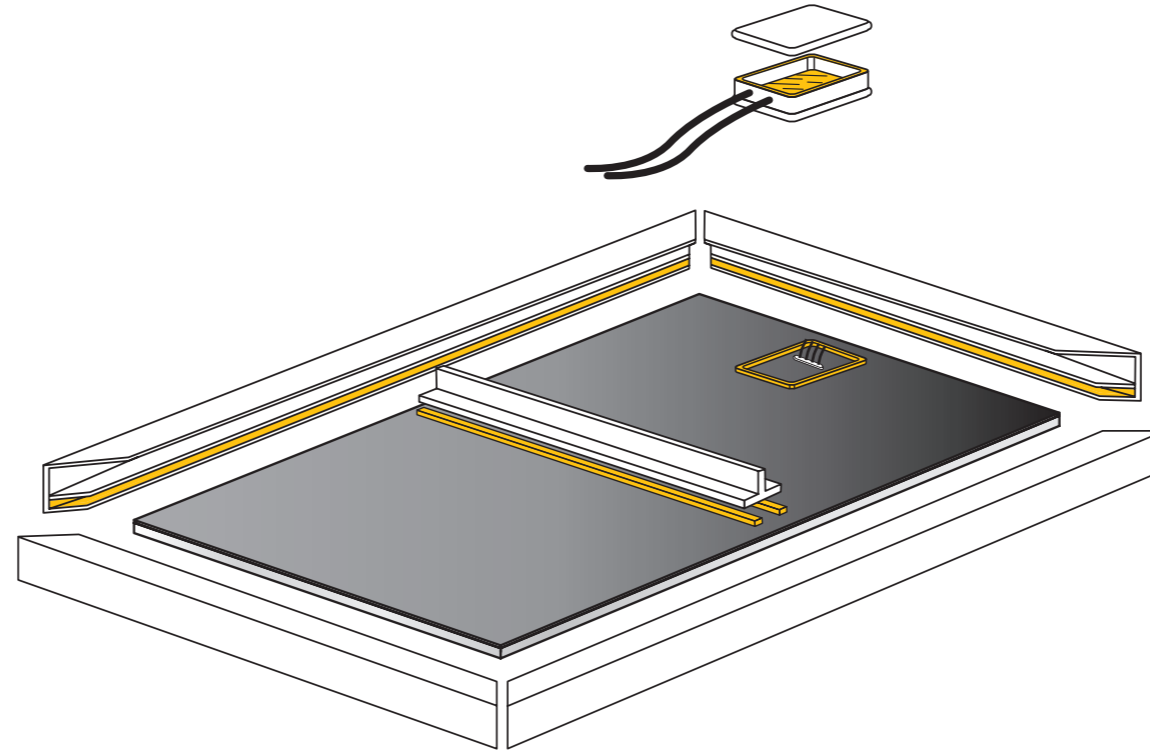

## Content

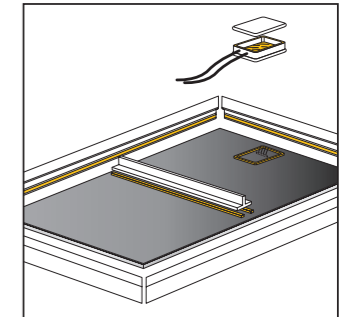

Photovoltaic Modules \_4

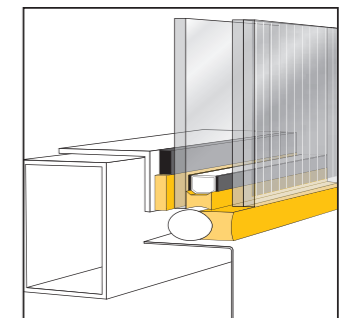

Building Integrated Photovoltaics \_6

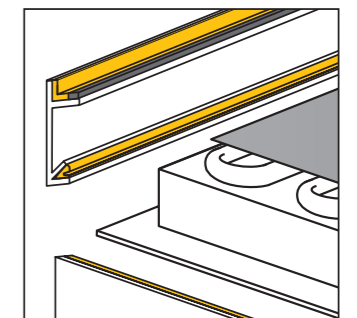
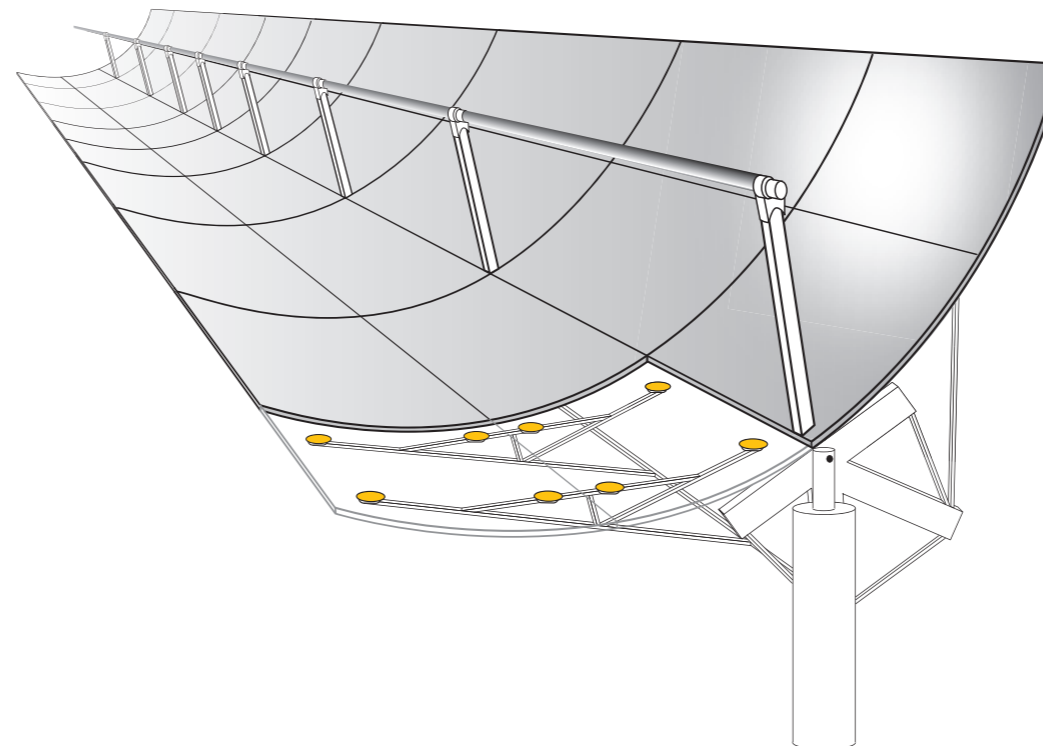

Solar Thermal Collectors \_7

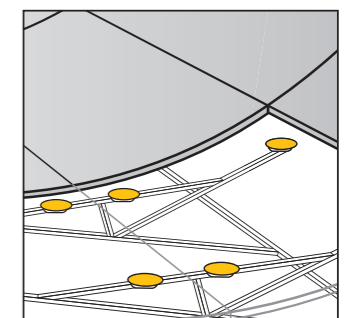

Concentrating Solar Power \_8

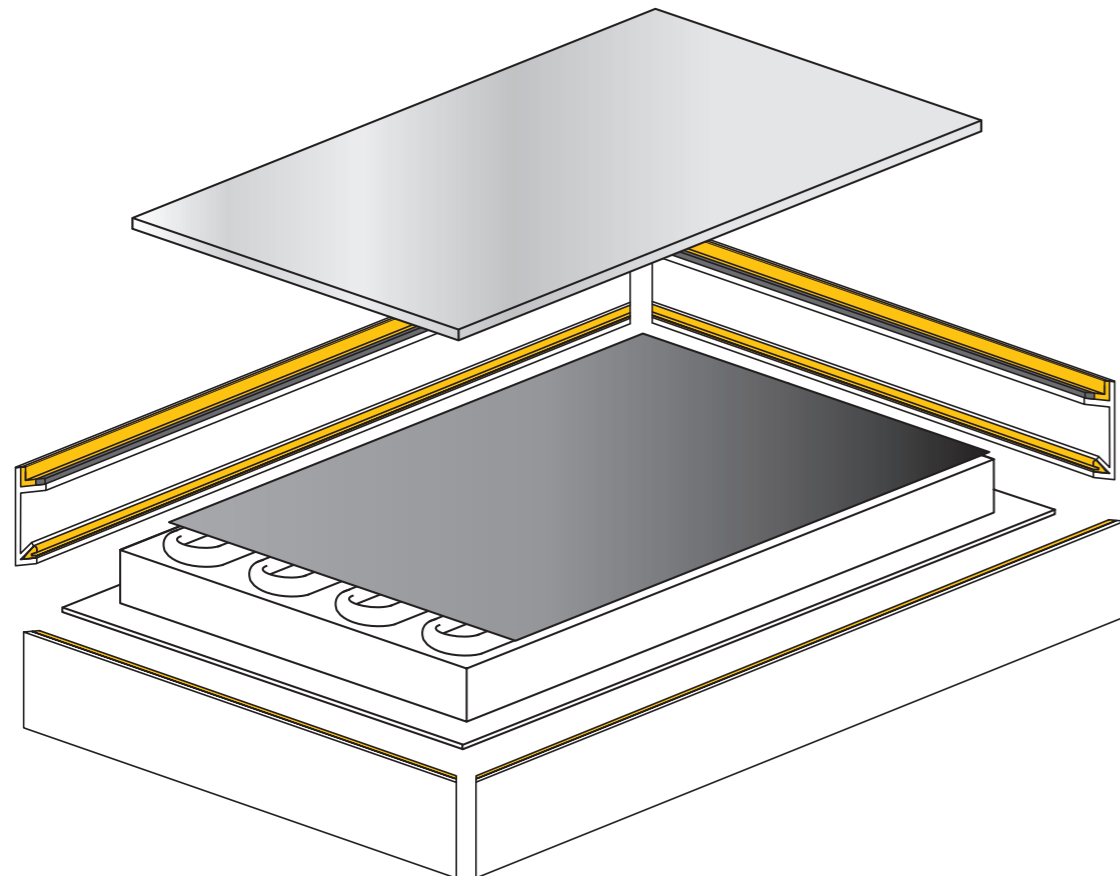

# Photovoltaic Modules

## Framing

Aluminum frames and back bars add structural strength to the photovoltaic module. They protect the glass edge and the delicate interiors as well as provide the means for installation. In addition to defending against moisture and environmental attack, durable and reliable sealants provide long-term bonding and a degree of protection against mechanical shock. Sika's fast curing structural adhesives and sealants not only carry out these essential functions, but also open up new design opportunities where reduced frame materials or larger module sizes become feasible.

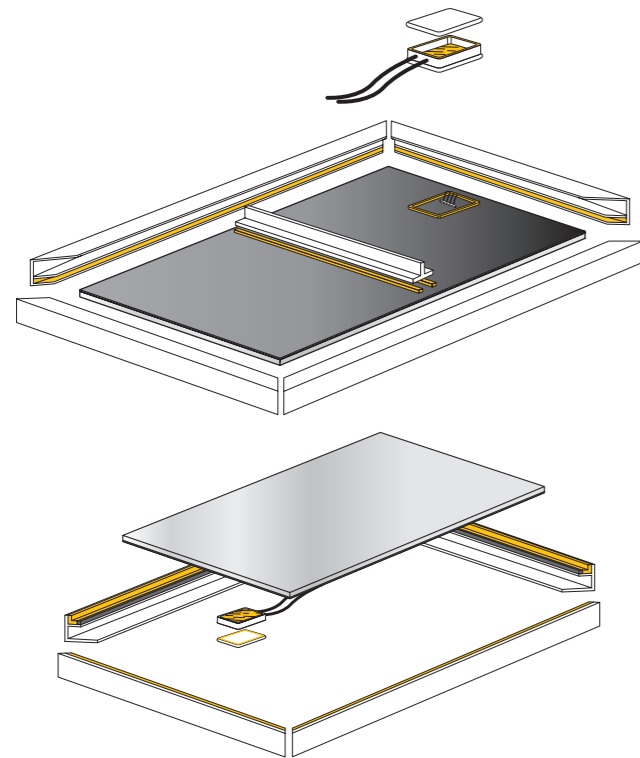

### System Benefits

- Shortens curing times for high production performance
- Allows simplified frame design
- Facilitates new frame designs without raised edges that trap dirt or water
- Simplifies automation of production
- Offers best in class load and weathering resistance
- Allows reduced materials and process costs
- Simplifies corner design thanks to structural bonding

## Bonding to the Substructure

The need for frames and clamps in assembling modules to a substructure is eliminated by the properties of the structural adhesive to strongly link the dissimilar components together; a clear benefit in reducing the system costs.

As stresses from wind, snow and other mechanical and environmental impacts are homogeneously distributed by the flexible adhesive, less tension occurs in the module, thereby improving its durability. This bonding system allows a greater freedom of design making a range of different construction methods feasible, especially for Building Integrated Photovoltaic (BIPV). Sika provides a range of structural adhesives with various curing speeds that allow both diverse production methods and on-site bonding.

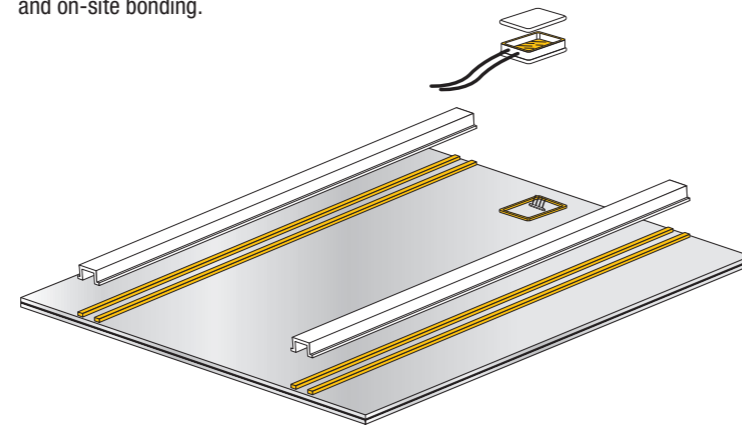

### System Benefits

- Eliminates the need for frame or clamps in mounting
- Gives high production efficiency thanks to fast curing systems
- Simplifies the design of mounting systems
- Flexible bonding eliminates stress peaks
- Saves material and labour
- Complies with the facade requirements of EOTA ETAG 002
- Gives greater freedom of design for BIPV
- Provides high burglary resistance
- Allows bonding both during production and on-site
- Fosters high automation possibilities

## Junction Box Potting and Sealing

On electrical systems that are exposed to environmental conditions, protection of the electrical connections is vital. A junction box sealant must exclude moisture, be flame retardant, and also be a good insulator. While it is essential that thoroughly proven and reliable systems are used for encapsulation and sealing, the materials must also be optimised for the different stages of the manufacturing process.

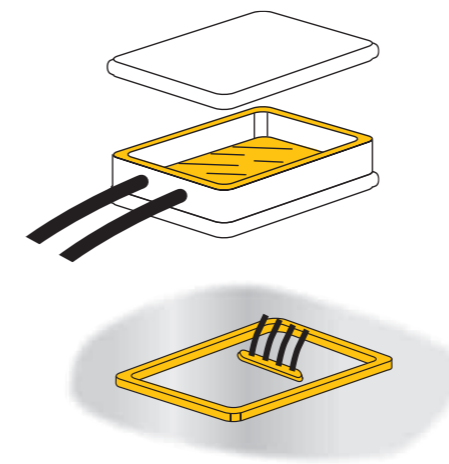

### System Benefits

- Shows durable water-tightness and insulation
- Shortens cycle times thanks to short “non-flow” and curing times for potting products
- Short curing times due to fast reacting products
- Provides long lasting environmental protection

## Flexible Thin Film

Flexible thin film system technology is becoming more established amongst the other photovoltaic systems. As it is a lightweight solution, it is especially applicable for weight sensitive applications like roofing.

However, even here, the bonding of the PV laminate to the sub-assembly is crucial. On the one hand the adhesive must be easy to use during construction and installation and on the other hand, it needs to be durable. Sika has developed a special bonding solution for this application that has a proven track record following many years in the field.

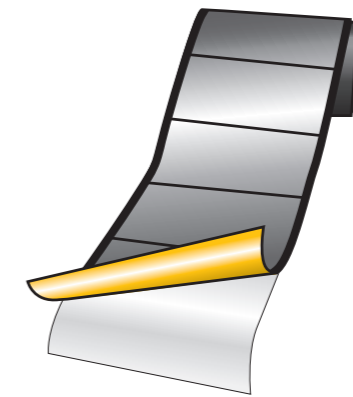

### System Benefits

- Ready to use system
- Full surface bonding
- Shows very good adhesion to many substrates
- Provides good durability
- Easy to use both during assembly and on site

## Building Integrated Photovoltaics

Building Integrated Photovoltaic (BIPV) is an area where architectural design meets ecological responsibility. A BIPV facade or rooftop can improve a building's energy consumption by providing both power and shade. There is also the challenge of getting the right balance between architectural appeal, optimal energy conversion and building functionality. Sika can call upon years of experience with facade and insulating glass design to help finalize a planned solution for solar integrated design.

Sika Facade System brochures and the Sika website ([www.sika.com](http://www.sika.com)) provide product details and example solutions.

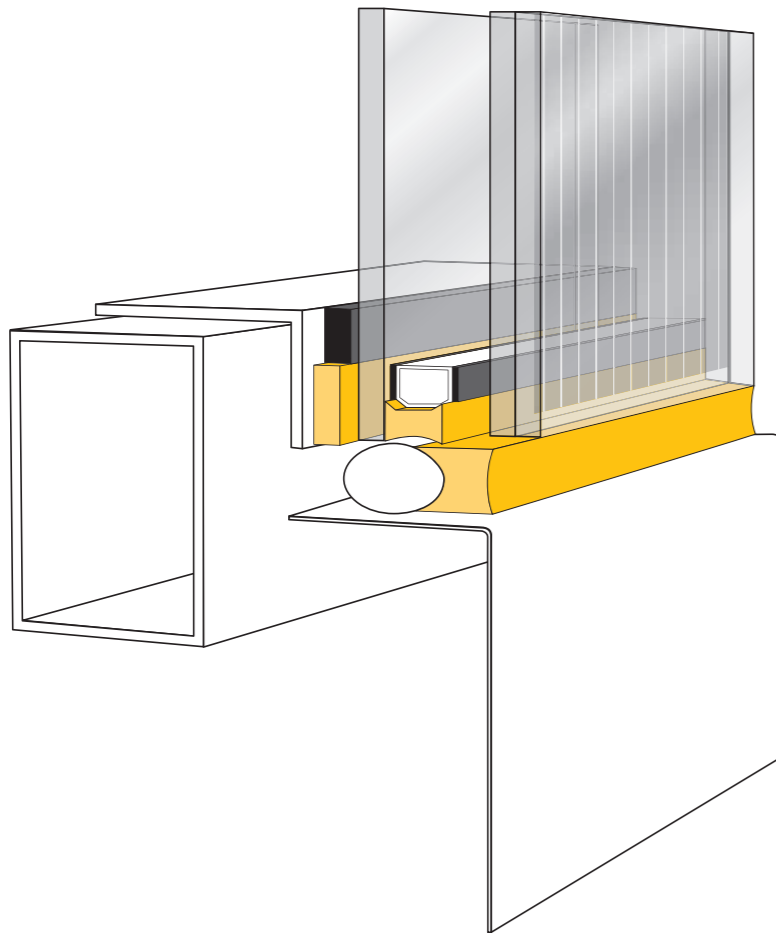

## Solar Thermal Collectors

The bonding technology is ideal for the automated production of flat collectors and translates to enhanced product quality and cost savings during the design and production phase. The simplified methods mean that the cover glass can be bonded directly to the frame or tray of the collector, thus avoiding the need for additional profiles, frames and dry gaskets. The process can also be entirely automated so that, together with the lower component count, substantial cost savings can be realized.

The approved and tested products ensure that vital joints are extremely durable and watertight, which is not always the case when using the conventional dry gasket method. With the elimination of the top frame, the solar panels not only look sleeker and more stylish, but they no longer have raised edges that trap dirt and water, and snow may easily slide off. The backs of the solar collectors can also be bonded in the same way thereby doubling the benefits and ensuring an overall weather-tight seal.

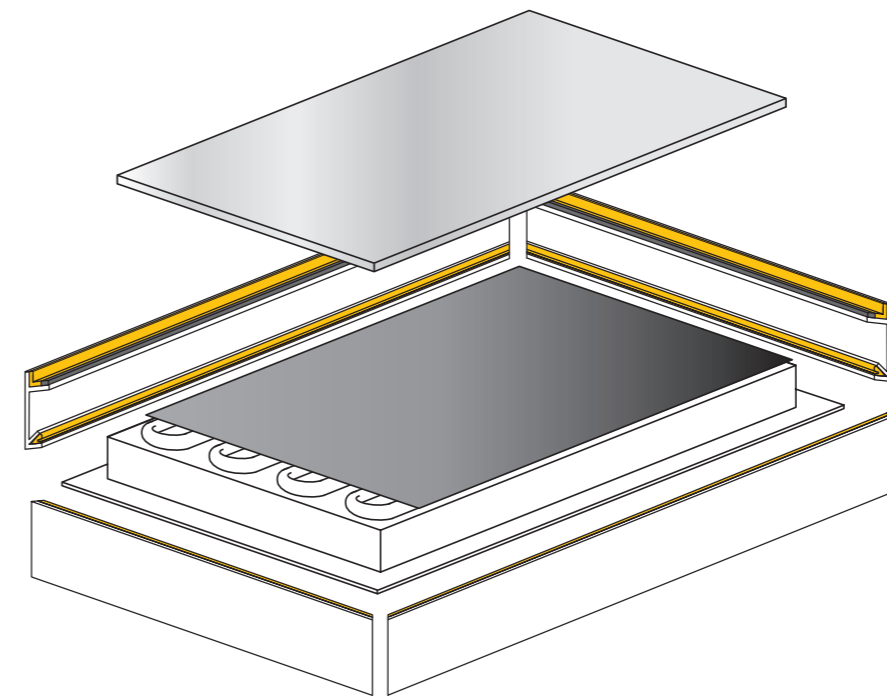

### System Benefits

- Facilitates frame design without raised edges that trap dirt or water
- Allow simple automation of production
- Does not require additional frames or gaskets
- Displays short curing times
- Best in class load and weathering resistance

# Concentrating Solar Power

Concentrating Solar Power plants require failure-proof components to ensure continuous power production and a safe return on investment. As a result, the adhesive to bond the mirror fixation to the mirror must show a high longevity and provide a scalable solution. These factors together with the harsh environment of the reflectors demand the use of proven systems.

The variety of fixation systems vary considerably, therefore Sika is providing an established range of adhesives and a comprehensive engineering support department to lead customers to the perfect product and application.

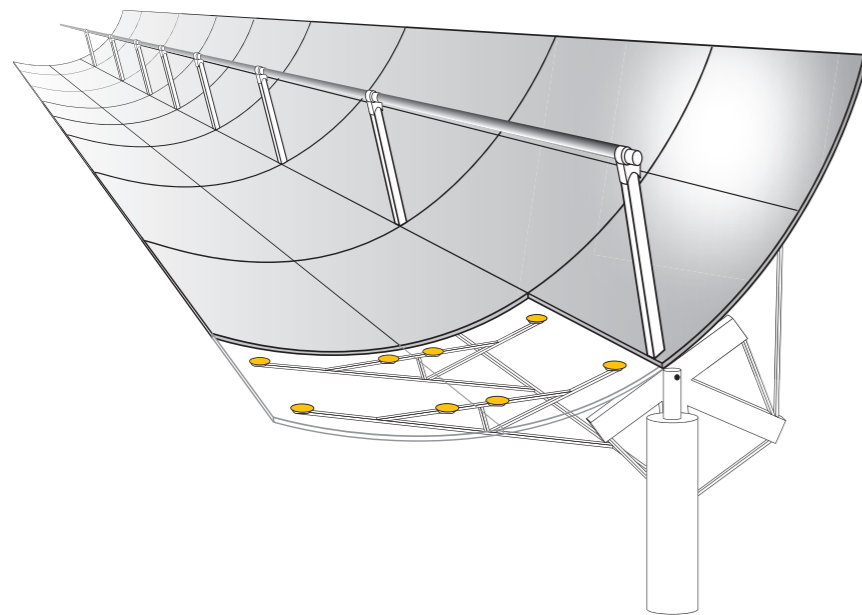

### System Benefits

- Eliminate the need for mechanical fixing of mirrors
- Simplifies the mounting system
- Allows savings in material and labour
- Creates fewer stress peaks in the unit
- Best in class load and weathering resistance
- Shows high automation index



# The Ideal Product for Every Application

	Applications	Grade	Advantages
<b>Sikasil® AS-785</b>	<ul style="list-style-type: none"> <li>- Structural bonding of mounting systems</li> <li>- Frame bonding</li> <li>- Junction box bonding</li> <li>- Solar thermal collector bonding</li> </ul>	2-component structural silicone adhesive	<ul style="list-style-type: none"> <li>- Fast curing and high strength</li> <li>- Outstanding UV- and weathering resistance</li> <li>- Low volatility</li> <li>- UL 94 V-0, RTI 105 °C</li> <li>- Meets EOTA ETAG 002</li> </ul>
<b>Sikasil® AS-770</b>	<ul style="list-style-type: none"> <li>- Structural bonding of mounting systems</li> <li>- Solar thermal collector bonding</li> </ul>	2-component structural silicone adhesive	<ul style="list-style-type: none"> <li>- High strength</li> <li>- Remains flexible over a wide temperature range</li> <li>- Superior durability</li> <li>- Low volatility</li> <li>- Meets EOTA ETAG 002</li> </ul>
<b>Sikasil® AS-70</b>	<ul style="list-style-type: none"> <li>- Structural bonding of mounting systems</li> <li>- Frame bonding</li> <li>- Junction box bonding</li> <li>- Solar thermal collector bonding</li> </ul>	1-component structural silicone adhesive	<ul style="list-style-type: none"> <li>- High strength</li> <li>- Superior heat resistance</li> <li>- Outstanding durability</li> <li>- Excellent adhesion</li> <li>- UL 94 HB, RTI 105 °C</li> <li>- Meets EOTA ETAG 002</li> </ul>
<b>Sikasil® GS-630</b>	<ul style="list-style-type: none"> <li>- Frame sealing</li> <li>- Junction box bonding</li> <li>- Solar thermal collector sealing</li> </ul>	1-component silicone adhesive	<ul style="list-style-type: none"> <li>- Fast curing</li> <li>- Excellent adhesion</li> <li>- High durability</li> <li>- Excellent flexibility</li> <li>- UL 94 HB, RTI 105 °C</li> </ul>
<b>Sikasil® WS-605 S</b>	<ul style="list-style-type: none"> <li>- Frame sealing</li> <li>- Solar thermal collector sealing</li> </ul>	1-component silicone sealant	<ul style="list-style-type: none"> <li>- High flexibility</li> <li>- Excellent adhesion</li> <li>- Non staining</li> <li>- Outstanding UV- and weathering resistance</li> </ul>
<b>Sikasil® AS-785 SL</b>	<ul style="list-style-type: none"> <li>- Potting of junction boxes</li> </ul>	2-component self levelling silicone sealant	<ul style="list-style-type: none"> <li>- Short non flow time</li> <li>- Fast curing</li> <li>- Consistent insulation properties</li> <li>- UL 94 V-0, RTI 105 °C</li> <li>- UL 746 C HWI 2, HAI 0, CTI 0</li> </ul>
<b>Sika® Lastomer-68</b>	<ul style="list-style-type: none"> <li>- Bonding of flexible thin film modules</li> </ul>	Ethylene Propylene Copolymer Tape	<ul style="list-style-type: none"> <li>- Broad adhesion range</li> <li>- Good durability</li> <li>- Excellent long term performance against creep and cold flow</li> <li>- Almost odourless</li> </ul>
<b>Product Benefits</b>	<ul style="list-style-type: none"> <li>• Approved technology in facade and solar industry</li> <li>• Outstanding performance under PV ageing conditions</li> <li>• Fast curing systems give high production output</li> <li>• Outstanding UV- and weathering resistance</li> <li>• Remain flexible over a wide temperature range</li> <li>• High durability</li> <li>• Low volatility systems</li> <li>• Certified and acknowledged products</li> </ul>		



# Our Performances – Your Benefits

Performance	Benefit
<b>Construction consultancy</b>	<ul style="list-style-type: none"> <li>– Review of existing solar systems relating to suitability for bonding</li> <li>– Advice on system improvements</li> </ul>
<b>Functional testing</b>	<ul style="list-style-type: none"> <li>– Support with prototyping</li> <li>– Functional tests / test plan of whole system for compatibility, adhesion and function</li> </ul>
<b>Application technology</b>	<ul style="list-style-type: none"> <li>– Active consulting, including the selection of application technology</li> <li>– System and equipment engineering / bonding technology</li> <li>– Support of equipment application procedures</li> </ul>
<b>Applicator training</b>	<ul style="list-style-type: none"> <li>– Preparation of operating manuals for bonding in conformity with ISO</li> <li>– Customer service</li> </ul>
<b>External approvals</b>	<ul style="list-style-type: none"> <li>– Best practice sample preparation</li> </ul>

## Our core competence – from Scratch to Field

Sika is a world leader in industrial high-end products with over 30 years of experience and offers its customers best practice solutions for bonding, sealing and protecting. Sika's solar engineers support module manufacturers with the development of the most appropriate solutions. Sika's application engineers achieve a smooth integration of the bonding technology into the customer's module fabrication or installation process.



# Focusing on Customers



Sika develops bonding and sealing solutions in close cooperation with its customers in the solar industry. To Sika, this means not only developing best-in-class technology solutions to match the customer's technical and commercial requirements, but also ensuring appropriate performance throughout the design, prototyping, validation and full production phases. Experts in Sika's R&D, Technical Service and System Engineering specialise in devising unique client-oriented solutions.

## Technical Service

Sika Technical Service teams are located around the world, and are dedicated to provide best practice selection, validation and application of Sika materials. By being located close to our customers, Sika Technical Service can ensure optimum local language communication and understanding throughout the technical application development process to ensure the best possible results.



## Design and System Engineering

State-of-the-art new adhesives and sealants, as well as innovative construction methods are currently in demand. There is also a growing need for design and application support. At Sika Solar Competence Centres, the best suitable solutions are developed in partnership with our customers to achieve the target results. Ultimately, this means reduced production costs, greater product reliability, improved aesthetic appeal and faster turn-around times, adding value to the activities of Sika customers.

# Sika Worldwide



Sika is a globally active company supplying the specialty chemicals markets. It is a leader in processing materials used in sealing, bonding, damping, reinforcing and protecting load-bearing structures in construction (buildings and infrastructure construction) and in industry (vehicle, building component and equipment production).

Sika's product lines feature high-quality concrete admixtures, specialty mortars, sealants and adhesives, damping and reinforcing materials, structural strengthening systems, industrial flooring and membranes. Subsidiaries in more than 70 countries worldwide and approximately 12,900 employees link customers directly to Sika.



© Sika Services AG / 07.2010 / OMS / RB



Our most current General Sales Conditions shall apply.  
Please consult the Product Data Sheet prior to any use.

[www.sika.com](http://www.sika.com)

**Innovation & Consistency** | since 1910